

Water Softeners Significantly Reduce Greenhouse Gases

The Effect of Hard Water on Household Consumables and Greenhouse Gas Emissions

By John and Candice Blount

Abstract

This study compares the consumption of detergent, bottled water and water heater energy against that of a residential ion exchange water softener and undersink reverse osmosis (RO) unit in a hard water environment. The reductions in consumables were quantified on an annual basis. The energy, raw materials and waste disposal for the consumables were calculated using a Life Cycle Assessment method using European model data. Consumption profiles were taken from American consumption data where possible.

Introduction

Human population growth fuels economic and industrial activity; as that increases, so does the consumption of raw materials and energy, creating greenhouse gases. Consequently, it is important that process technologies (either old or new) be evaluated for their overall effect on greenhouse gas emissions.

The everyday usage of detergents, cleaning agents, heated water and bottled water all have a quantifiable environmental impact. Each is affected by the quality of the water used. In a hard water environment, the amount of product or energy will increase, as in

the case of detergent and energy for hot water. Hard water is documented to have adverse effects on detergent performance and energy efficiency in water heaters. Also well documented is the growth in bottled water consumption over the last 10 years.

Modeling using the Life Cycle Assessment

The Life Cycle Assessment (LCA) is a methodology developed to evaluate the mass balance of a system's inputs and outputs and to organize them into an environmental theme (see Figure 1). The system used in this study was the effect a residential water softener would have on consumption and obsolescence of products, then converting this data into greenhouse gas output.

A growing number of companies are making policy commitments to address the environmental implications of their products using the LCA approach. It can strengthen and enrich other environmental management initiatives. LCA has become a key focus in environmental policy making and sustainability reporting. Greenhouse gas reduction and management involves a shift away from end-of-pipe or stack controls towards actions that avoid the creation of the problem.

Editor's note: As consumers are more continuously assaulted with messages about the negative effects of water softeners, wouldn't it be wonderful if you could tell them of some environmental benefits produced by your products?

Now you can. The father and daughter team of John and Candice Blount, both Chemical Engineers, found themselves wondering about the true environmental cost of water softeners and ROs because they knew that untreated hard water created significant costs, like increased detergent use and decreased appliance life. Rising bottled water sales were rarely presented in terms of true environmental impact, which also intrigued the authors.

John had used Life Cycle Analysis in several environmental projects, so he wondered if any such calculation had been done in our industry. He asked manufacturers he met at Aquatech Amsterdam, dealers at Texas WQA, manufacturers he visited here in the states at WQA Aquatech. None knew of anyone who had done such a study, so John and Candice Blount got busy.

Hundreds of hours of research later, they determined that when all data has been considered, in a hard water area, using a water softener and RO actually reduces greenhouse gases in an amount equivalent to getting one-and-a-third cars off the road for an entire year!

Tell your potential customers. Tell your existing customers. Tell your elected officials and utility legislators. And don't forget to tell your kids! You will want to keep a copy of their study on hand—contact us for a PDF.

The use of a residential water softener and undersink RO to facilitate a reduction in consumables can be an important part of a residential greenhouse gas reduction program.

Goal

The main goal of the work reported in this study is to analyze the environmental impact in terms of greenhouse gas contributions of an American family of four in consumptive products that are affected by use or consumption in a hard water environment. A secondary goal is to document how a water treatment system theoretically affects the environment from a greenhouse gas emissions perspective.

Description of system studied

The consumables affected by the use of a residential water softener in a hard water environment studied in this system are:

- laundry detergent use,
- hot water production,
- bottled water consumption.

The database constructed includes the following phases of the consumables: raw materials (extraction of raw materials and manufacturing), manufacturing into finished goods, packaging, distribution, use and disposal. The data gathered for the manufacturing, packaging and transportation of consumables is representative of European countries. The energy and disposal data are more specifically regional.

The consumables data has been

constructed in a series of steps; the first is the raw materials for the manufacturing process of the consumable. This is based on the average annual consumption or use. The second step is the manufacturing or processing of the raw materials to the end-use product; the third includes packaging. The fourth step is transport to distribution and marketing. The fifth step is the end use by the consumer, followed by the sixth step, disposal (see Figure 2). In each step, the energy and environmental emissions associated with the process are calculated.

Functional unit

The results are reported on a mass

basis in carbon dioxide pound equivalents. For illustrative purposes, the LCA for all the systems reported is the consumptive materials affected by a water softener of an American family of four in a one year period.

Data and data quality requirements

An important issue in considering the data of this study is its reliability. In a complex study with several sources of data, the accuracy of the data and how it may be projected on an American use model affects the conclusions.

Bottled water data: The consumption data used for the bottled water was the most recent as published by the International Bottled Water Association (IBWA). The bottled water LCA data was derived from a 1994 Belgium study of a proposed eco-tax on PVC bottles. The study group consisted of PVC and PET one-way bottles and glass return bottles for mineral water. The PET bottle data was used in this study. Transportation, distribution and disposal data was not available and was not included in this database and calculation. US databases were not available. The bottled water usage data was also taken from the IBWA. The data quality is high.

Detergent: This information was compiled over the last 10 years by Procter & Gamble and Franklin & Associates. The methodology used by Franklin & Associates has been documented by the US EPA as a guideline for LCA determination. The data provided is for US manufacturing and the energy grid and disposal characteristics were from a European data set. The consumption data is extrapolated from a US data source.

Water heater: Data documented through a University of New Mexico study. The electric consumption and total BTU savings were then converted into carbon dioxide equivalents.

Manufacturing/filling process: The manufacturing process for the detergents was compiled from the German Detergent Association (IKW). The quality of the data is medium, due to not correlating with current US detergent production data. This data covers granular powders¹. The bottled water filling process was documented using a Dutch model; that data quality is high.

Packaging: While the quality of this data is high, it does not include any recycled materials or make provisions for recycling in the disposal portion of the assessment.

Figure 2.

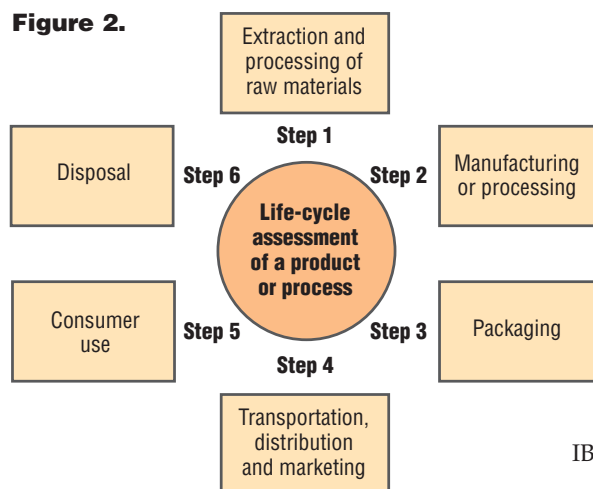
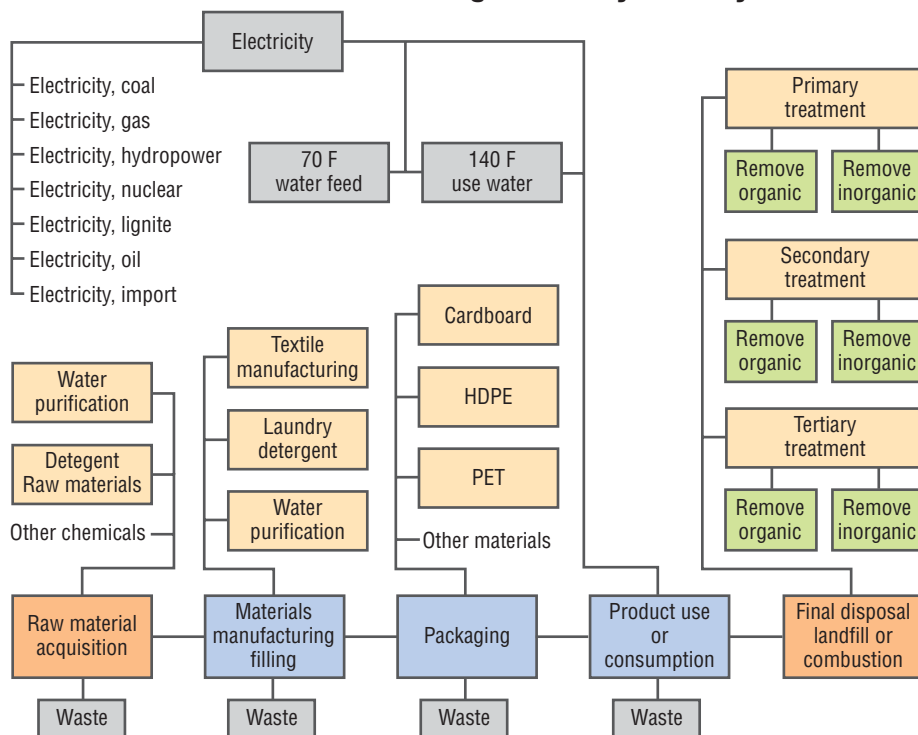

Figure 1. General material flow for cradle-to-grave life cycle analysis



Detergent usage: Once the products are manufactured, they reach consumers through various distribution networks. The transportation carbon inventories were estimated using known data from SimaPro. The data for the consumer use laundry detergent portion was acquired from a European model based on the amount of chemicals used per wash load (this data should be considered medium, due to different countries having different laundering needs). Additionally, habits such as hand washing; pre-washing, pre-soaking, pre-treating stains, etc. are not included in this system.

The amount of chemicals per wash load is indicated on the package. The wash temperature was taken from a 1997 Belgian study².

Energy consumption data for the washing cycle was taken from the European Washing Machine Manufacturer Association. The data quality is considered high.

Disposal: This is region-specific and does not include any recycling or reuse parameters. It does include primary (settler) and/or secondary (activated sludge) possibly followed by tertiary (sand filtration and nutrient removal). Other types of wastewater (septic tanks, oxidation ditches, soils, etc.) have not been considered. The data quality is considered low.

Inventory analysis and calculation procedures

All energy, raw material consumption and environmental emissions were allocated to a product or system on a mass basis, according to the specified unit. The units were then converted to carbon dioxide equivalents using standard conversion methods available through published sources.

Impact assessment

This was limited to the inventory of consumables described in this system. It is beyond the scope of this article to discuss the merits or limitations of a complete LCA. Accurate data from the water conditioning equipment and resin manufacturers, salt suppliers and other ancillary product suppliers needs to be accounted for. Additionally, the obsolescence of plumbing, appliances and other textiles need to be accounted for to get a complete picture.

Table 1. PET one-way bottles for mineral water¹

Type of pollution	Amount of pollution	CO ₂ equiv./ lbs.
Use of fossil energy (MJ)	2,750	1,653 ²
Use of process water (kg)	400	NA
Global warming effect (kg CO ₂ eq)	210	462
Photochemical effect (g C ₂ H ₄ eq)	370	NA
Acidification (g SO ₂ eq)	950	NA
Chemical oxygen demand (COD g)	70	NA
Non-radioactive solid waste (kg)	15	NA
Radioactive solid waste (g)	4.8	NA
Air pollution (1,000 m ³ units for air)	250	NA
Water pollution (m ³ units for water)	25	NA
Dioxin 1 (ng TEQ)	3	NA
Dioxin 2 (ng TEQ)	0.02	NA
Total		2,115 lbs.

Calculations

Bottled water: 2.5 half-liter bottles of water are used per day³. The CO₂ equivalent of 1,000 liters of bottled water in PET (polyethylene terephthalate) was conducted to reveal the following (see Table 1).

Calculation for CO₂ equivalent:

- Caps, labels and case packaging were not included in the calculation.

- The IBWA year 2000 data revealed that the average American consumed 2.3 bottles of water per day. A family of four would then consume (2.3/day) (4) = 9.2/day; this would equate to (9.2) (365) days/year = 3,358 liters per year. A reduction in purchasing would eliminate (2,115 lbs. CO₂ Eq./1,000 liters) (3,358 liters per year) = 6,716 lbs. CO₂ Equivalent.

Laundry soap usage⁶

Total greenhouse gas emissions eliminated with softened water:

- Total CO₂ equivalents in pounds per

1,000 wash loads = 1,1856.6.

- Reduction in laundry detergent is 66 percent.⁸

- Total reduction is 7,825.4 pounds per 1,000 wash loads (11,856.6) (0.66).

- The estimated annual number of wash loads per American family of four is 520.

- Total pounds CO₂ eliminated is 520/1,000 (7,825.4) = **4,069.2 lb. CO₂ Equivalent.**

Hot water use calculations

- The average American family of four uses 80 gallons per day of hot water per person.⁹ Assuming 70°F incoming water and heating to 140°F.

- The number of BTUs per day is (140°F - 70°F) (8.328 lbs./gallon water) (80 gallons/day) = 46,636.8 BTUs /day.

- The number of BTUs per kWh is 3,413; therefore, kWh per year is (46,636.8 BTU/day)/(3,413 BTU/kWh) (365 days/year) = 4,987.5 kWh.

- Assuming 83 percent efficiency with electric¹⁰ and 26 percent loss due to hard water fouling¹¹: (4,987.5 kWh/0.83) - (4,987.5 kWh/0.83) (1-0.26) = 2,111 kWh.

- Carbon dioxide equivalents = (2,111 kWh) (2.1476 lbs. CO₂/kWh) = **4,533.5 lbs CO₂ Equivalent.**

Total for all systems studied

Bottled water usage:

6,716 lbs. CO₂ Equivalent

Laundry detergent usage:

4,069 lbs. CO₂ Equivalent

Water heater efficiency gain:

4,534 lbs. CO₂ Equivalent

Total:

15,319 lbs. CO₂ Equivalent

Table 2. CO₂ pound equivalents

Life cycle stage	Raw material supply	Manufacture	Consumer use	Disposal	Packaging
Energy and emissions					
Energy					
Process energy	1,027.2	148.5	2,336.2	53.5	0
Transport energy	154.5	0	0	0	0
Feedstock	404.5	0	0	0	0
Primary energy	1,545.5	148.5	8,144.5 ¹	154.5	41.6
Solid waste					
Sludge solids	17.8	0	0	396.2	0.9
Other solids	573.8	33.2	3,014.7	56.5	140.7
Air emissions					
CO ₂	275.0	29.3	851.4	35.6	4.9
CH ₄	11.5	0	46.4	5.4	0
NO ₂	254.0	21.4	597.8	15.6	6.0
Totals	4,263.8	380.9	6,846.5	171.3	194.1

Results and discussion

The total annual carbon dioxide reduction of 15,319 lbs equates to what 1.3 vehicles would emit annually driving about 12,100 miles¹².

- Average personal vehicle in the US travels 12,100 miles. (Source: US EPA greenhouse gas climate change calculator).

- CO₂ generated per gallon of gasoline = 19.52 lbs. (Source: U.S. Energy Information Administration <http://www.eia.doe.gov/oiaf/1605/coefficients>)

- Equivalent gallons of gasoline: (15,319 lbs. CO₂ saved)/19.56 lbs. CO₂/gallon gasoline = 783.17 gallons gasoline.

- Equivalent miles driven at 20 miles per gallon: (783.17 gallons) (20 miles/gallon) = 15,663.4 miles.

- Equivalent in vehicles: (15,663.4 miles) (12,100 miles per vehicle traveled per year) = 1.3 vehicles per year.

To illustrate the LCA, the results in this database are a hypothetical use of laundry detergent consumption, hot water energy use and bottled water consumption. The laundry detergent use data was taken from a European model and does not reflect an American laundry consumption model. The use profile for an American family is generally larger in amounts due to the predominant use of top-loading washing machines in America. American usage data was not available and would skew the carbon dioxide number upwards. The energy profile for hot water was taken from a weighted average of the electrical grids in the US. A coal fired electric generation plant would have a higher CO₂ equivalent profile than electricity generated from a renewable source such as wind or solar.

Limitations of this LCA system

- The detergent usage was taken from a European model and does not reflect American product usage.

- The input data does not include: residential ion exchange water softener with carbon and brine tank; undersink RO unit; brine make-up materials (sodium

chloride or potassium chloride); resin; activated carbon.

- The output data does not include reductions in: plumbing fixture obsolescence; textile obsolescence; household cleaner usage; appliance obsolescence; water heater obsolescence.

The omission of the above referenced input and output data is due to a lack of credible data. An assumption can be made that the water treatment equipment LCA would have a negligible effect on the overall carbon dioxide number when offset by the outputs.

Conclusion

The LCA used in this study takes into account manufacturing, raw material procurement and processing, end processing, transportation, consumer use and disposal. The consumer use and disposal is region-specific. The analysis presented here clearly demonstrates that a residential water softener and undersink RO unit used in a hard water environment will reduce consumption and obsolescence and can be directly correlated to a reduction of greenhouse gas emissions.

References

1. SETAC (1993): Guidelines for Life Cycle Assessment: a code of practice. Society of Environmental Toxicology and Chemistry, Pensacola, Fla., Sesimbra, Portugal.
2. L' Association Internationale de la Savonnerie, de la D'etergence et des Produits d'Entretien (AISE), 1997.
3. IBWA.
4. VITO investigation of packaging of 1,000 Liter non sparkling mineral water Dutch Governmental Research Institute. February, 1994.
5. Energy Information Administration, Annual Energy Review 2000 DOE/EIA.-0384, (2000); (Washington, DC, August 2001) at line 223,337; <http://www.eia.doe.gov/aer/>.
6. Based on LCI of 1,000 washloads. Study Conducted By Procter & Gamble, 1999.
7. Note: Number was not used in total calculation.
8. Use of Detergents, Krystyna, Dvoik, Eng. D. Sc. in carbon dioxide equivalents.
9. Oregon State University Extension Program, <http://extension.oregonstate.edu>.

10. U.S. Department of Energy, Building Technologies Program, Conventional Water Heater Efficiency 06.12.06.

11. Softened Water Energy Savings Study Controlled Experimental Testing Program on Household Water Heaters, Engineering Experiment Station, New Mexico State University, Willie P. Isaacs, Gail R. Stockton, 1978.

12. U.S. EPA, <http://www.epa.gov/climatechange/emissions/index.html>.

About the authors

◆ John Blount, President and CEO of Pure & Gentle Inc. in Seguin, Texas, has been involved in developing products for the water treatment industry since 1986. He holds a BS in biochemistry, an MS in chemical engineering and has published articles on enzyme research in various scientific journals. Blount is Product Development Manager at Pilot Chemical and Technical Director at Cal-Tex Coatings. He is also a Member of the Board of the Texas Recycling Council and Keep America Beautiful, as well as being an active member of WQA and TWQA. Blount's expertise includes product and process development of FDA- and EPA-regulated products. He can be reached by telephone at 830/379-1937, or via e-mail Johnb@pgitx.com or visit the company's website www.pgitx.com



◆ Candice Blount is Vice President of Operations, Pure & Gentle Inc. Since 2002, she has been actively involved in the development of numerous products for the water treatment industry and oversees regulatory processes for the company. Blount holds a BS in chemical engineering and is completing requirements for an MBA in finance. Like her father John, she is an active member of WQA and TWQA. Her email is candiceb@pgitx.com. All other contact information is the same as above.



Reprinted with permission of Water Conditioning & Purification Magazine ©2009.
Any reuse or republication, in part or whole, must be with the written consent of the Publisher.